

SURGING

紹 鑫 實 業



SurgeArresters

陶瓷气体放电管

SE6 Series

Features

- Surface Mounting Design 6.8×3.5×3.5mm Current
- Current Handling Capability 6,000A @ 8/20μ s
- Low Capacitance and Insertion Loss
- Fast Response and Long Service Life
- Reliable to Protect Electrostatic Surge
- Moisture sensitivity level: Level 1

Exterior

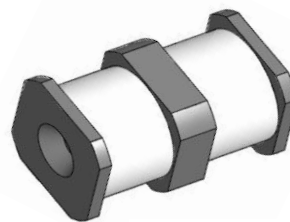

SMD

Application Information

- xDSL

Package (Top View)

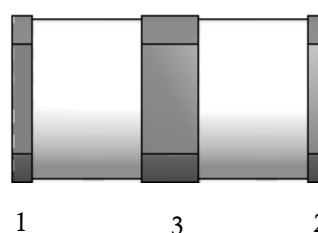

Agency Approvals

Icon	Description
RoHS	Compliance with 2011/65/EU
HF	Compliance with IEC61249-2-21:2003
	Mean lead free

Schematic Symbol

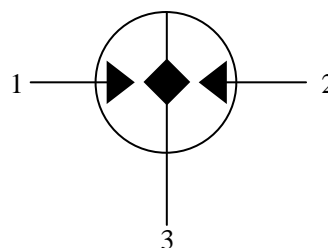

Electrical Parameter

DC Breakdown Voltage ^{1)2) 3)4)}	100V/s	72-108	V
Impulse Spark-over Voltage ⁴⁾	At 1kV/μs	for 99 % of measured values	≤ 650 V
	At 1kV/μs	Typical values of distribution	≤ 600 V
Impulse Discharge Current ⁵⁾	8/20μs	6,000	A
Insulation Resistance	DC=100V	≥1	GΩ
	C(1MHz)	VDC=0.5V	≤1.0 pF
Weight		~0.33	g
Operating And Storage Temperature		-40-+90	℃
Marking		Without	

1) At delivery AQL 0.65 level II ISO 2859

2) In ionized mode

3) Terms and waveforms in accordance with ITU-T Rec. K. 12; IEC 61643-21

4) Tip electrode "1" or "2" to center electrode "3"

5) Total Currents through center electrode 2, half value through each Tip electrode "1" "2".

Part Numbering System

SE60 90X

(1) (2)

(1) SURGING 3-Electrode SMD Gas Discharge Tube

(2) DC Breakdown Voltage, e.g., 90X=90V

Product Characteristics

Lead Material	Copper
Body Material	Ceramics
Terminal Finish	100% Matte-Tin Plated

Environmental Reliability Characteristics

Testing items	Technical standards
High Temperature Storage Test	Temperature: 90°C Time: 2H
Low Temperature Storage Test	Temperature: -40°C Time: 2H
Vibration	Frequency: 10-500Hz Amplitude: 0.15mm Time: 45mins
Resistance of soldering heat	Temperature: 260±5°C Time of dip soldering: 10s, 1time

Note: Up-screen program can be specified by customer's request via contacting SURGING service

Solderability Test

Solderability	Solder Pot Temperature:	245°C ± 5°C
	Solder Dwell Time:	4-6 seconds

Product Dimensions

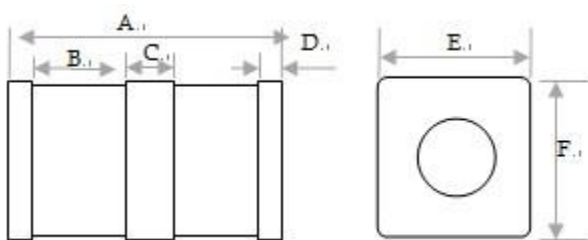

REF	mm	inch
A	6.8±0.2	0.268±0.008
B	2.4±0.15	0.094±0.006
C	1.2±0.1	0.047±0.004
D	0.4±0.1	0.016±0.004
E	3.5±0.15	0.138±0.006
F	3.5±0.15	0.138±0.006

Recommended Soldering Pad

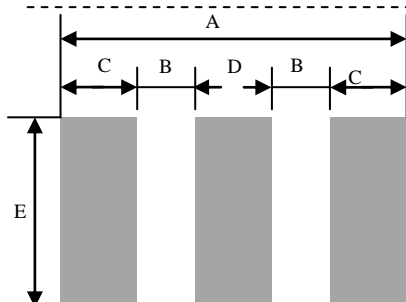

REF	mm	inch
A	8.10	0.217
B	1.75	0.138
C	1.40	0.055
D	1.80	0.071
E	4.20	0.165

Reflow Profile

Reflow Condition		Pb-Free assembly
Pre Heat	Temperature Min	150 °C
	Temperature Max	200 °C
	Time (min to max)	60 – 180 secs
Average ramp up rate (Liquids) Tmp (T _L) to peal		3 °C/second max
T _S (max) to T _L - Ramp-up Rate		3 °C/second max
Reflow	- Temperature (T _L) (Liquids)	217 °C
	- Temperature (T _L)	60 – 150 seconds
Peak Temperature (T _P)		260+0/-5 °C
Time within 5 °C of actual peak Temperature (t _p)		8 – 20 seconds
Ramp-down Rate		6 °C/second max
Time 25 °C to peak Temperature (T _P)		8 minutes Max.
Do not exceed		260 °C

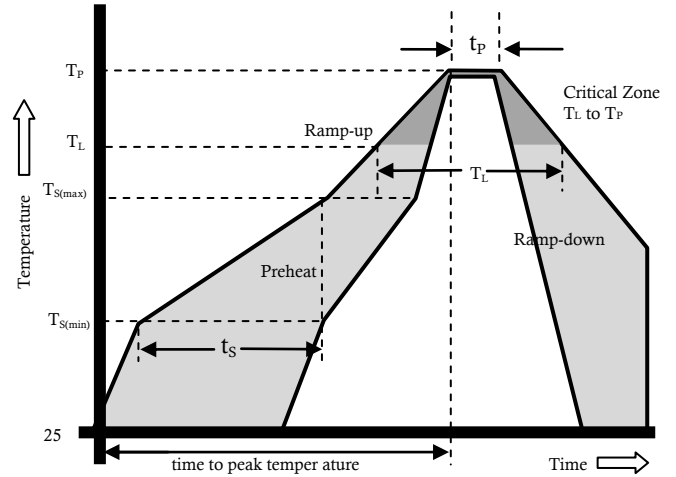

Package Reel Information

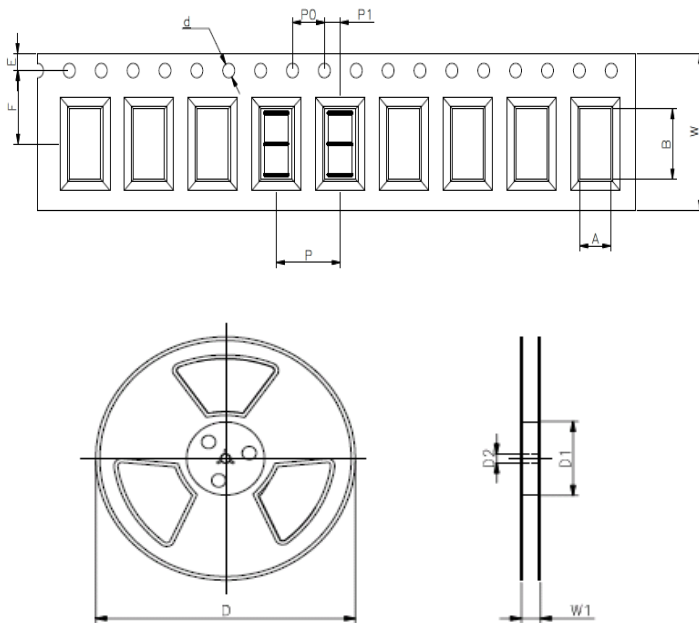

REF	mm	inch
A	3.9±0.2	0.154±0.008
B	7.0±0.2	0.276±0.008
d	Φ1.5±0.1	Φ0.059±0.004
E	1.75±0.1	0.069±0.004
F	7.5±0.1	0.295±0.002
P	8.0±0.1	0.315±0.004
P0	4.0±0.1	0.157±0.004
P1	2.0±0.1	0.079±0.004
W	16.0±0.3	0.63±0.012
D	Φ330.0	Φ13.0
D1	Φ50Min	Φ1.97Min
D2	Φ13±0.15	Φ0.512±0.006
W1	20.8±2.0	0.819±0.079

OUTLINE	REEL (PCS)	PER CARTON (PCS)	REEL DIAMETERS (mm)	CARTON SIZE(mm)		
				L	W	H
TAPING	2,000	32,000	330	360	360	380