

Surface Mountable PTC Resettable Fuse: JK-SMD0603 Series

Features:

- ✧ RoHS Compliant & Halogen Free
- ✧ faster tripping, 0603 Dimension, Surface mountable, Solid state
- ✧ Operation Current: 0.05A~0.35A
- ✧ Maximum Voltage: 6V~15Vdc
- ✧ Operating Temperature: -40℃ TO 85℃



Product Dimensions

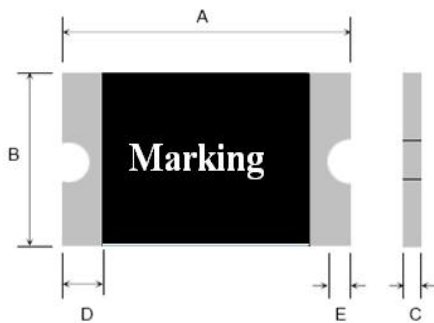

Unit : mm

Terminal pad materials :Tin-Plated Nickle-copper  
 Terminal pad solderability : Meets EIA specification  
 RS 186-9E and ANSI/J-STD-002 Category 3.

Model	Marking	A		B		C		D		E
		Min	Max	Min	Max	Min	Max	Min	Max	Max
JK-SMD0603-005	1	1.45	1.85	0.65	1.05	0.40	0.75	0.15	0.50	0.40
JK-SMD0603-010	1	1.45	1.85	0.65	1.05	0.40	0.75	0.15	0.50	0.40
JK-SMD0603-020	2	1.45	1.85	0.65	1.05	0.40	0.75	0.15	0.50	0.40
JK-SMD0603-025	3	1.45	1.85	0.65	1.05	0.40	1.00	0.15	0.50	0.40
JK-SMD0603-030	5	1.45	1.85	0.65	1.05	0.40	1.00	0.15	0.50	0.40
JK-SMD0603-035	5	1.45	1.85	0.65	1.05	0.40	1.00	0.15	0.50	0.40

Thermal Derating Chart-IH (A)

Model	Maximum ambient operating temperatures (℃)								
	-40	-20	0	25	40	50	60	70	85
JK-SMD0603-005	0.07	0.06	0.055	0.05	0.04	0.35	0.3	0.25	0.15
JK-SMD0603-010	0.14	0.12	0.11	0.1	0.8	0.7	0.6	0.5	0.3
JK-SMD0603-020	0.28	0.25	0.23	0.20	0.17	0.14	0.12	0.10	0.07
JK-SMD0603-025	0.35	0.31	0.29	0.25	0.21	0.18	0.15	0.13	0.09
JK-SMD0603-030	0.42	0.38	0.35	0.30	0.26	0.21	0.18	0.15	0.11
JK-SMD0603-035	0.47	0.44	0.39	0.35	0.30	0.27	0.24	0.20	0.14



## Electrical Characteristic

Model	$V_{max}$	$I_{max}$	$I_{hold}$	$I_{trip}$	$P_d$	Maximum time to trip		Resistance	
	(Vdc)	(A)	(A)	(A)	Max. (W)	Current	Time	$R_{min}$	$R_{max}$
						(A)	(Sec)	( $\Omega$ )	( $\Omega$ )
JK-SMD0603-005	24.0	20	0.05	0.15	0.50	0.2	1.00	3.0	35.00
JK-SMD0603-010	15.0	40	0.10	0.30	0.50	0.5	1.00	0.9	8.00
JK-SMD0603-020	9.0	40	0.20	0.40	0.50	1.00	0.60	0.55	3.50
JK-SMD0603-025	9.0	40	0.25	0.55	0.50	8.0	0.08	0.500	3.00
JK-SMD0603-030	6.0	40	0.30	0.70	0.50	8A	0.10	0.300	2.00
JK-SMD0603-035	6.0	40	0.35	0.75	0.50	8A	0.10	0.200	1.40

## Part Numbering System

JK- SMD0603 - □□□

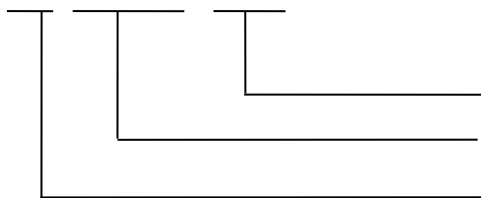

Holding current Rating

0603 Dimension Surface Mount Device

JK mark

## Test Procedures And Requirements

Test	Test Conditions	Accept/Reject Criteria
Resistance	In still air @ 25 °C	$R_{min} \leq R \leq R_{max}$
Time to Trip	Specified current, $V_{max}$ , 25 °C	Tmaximum Time to Trip
Hold Current	30min, at $I_H$	No trip
Trip Cycle Life	$V_{max}$ , $I_{max}$ , 100cycles	No arcing or burning
Trip Endurance	$V_{max}$ , 1 hours	No arcing or burning

## Physical Characteristics and Environmental Specifications

Terminal materials :	Tin-Plated Nickle-copper
Soldering zone	Meets EIA specification RS 186-9E and ANSI/J-STD-002 Category 3.

### Environmental Specifications

Test	Conditions	Resistance Change
Passive aging	85 °C ,1000hours	±10%
Humidity aging	85 °C /85%RH.1000 hours	±5%



Thermal shock	MIL-STD-202,Method 107G +85 C /-40 C ,20times	-30% typical resistance change
Solvent Resistance	MIL-STD-202,Method 215	no change
Vibration	ML-STD-883C,Test Condition A	No chage

## Electrical Specifications:

$I_{hold}$  = Hold Current. Maximum current device will not trip in 25°C still air.

$I_{trip}$  = Trip Current. Minimum current at which the device will always trip in 25°C still air.

$V_{max}$  = Maximum operating voltage device can withstand without damage at rated current ( $I_{max}$ ).

$I_{max}$  = Maximum fault current device can withstand without damage at rated voltage ( $V_{max}$ ).

$P_d$  = Maximum power dissipation when device is in the tripped state in 25°C still air environment at rated voltage.

$R_{i_{min/max}}$  = Minimum/Maximum device resistance prior to tripping at 25°C.

$R_{I_{max}}$  = Maximum device resistance is measured one hour post reflow.

## Recommended pad layout (mm)

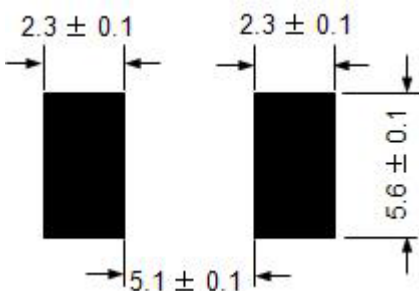

## Solder reflow conditions

Profile Feature	Pb-Free Assembly
Average ramp up rate ( $T_{S_{MAX}}$ to $T_p$ )	3°C/second max.
<b>Preheat</b>	
• Temperature min. ( $T_{S_{MIN}}$ )	150°C
• Temperature max. ( $T_{S_{MAX}}$ )	200°C
• Time ( $t_{S_{MIN}}$ to $t_{S_{MAX}}$ )	60-120 seconds
<b>Time maintained above:</b>	
• Temperature ( $T_L$ )	217°C
• Time ( $t_L$ )	60-150 seconds
<b>Peak/Classification temperature (<math>T_p</math>)</b>	260°C
<b>Time within 5°C of actual peak temperature</b>	
Time ( $t_p$ )	30 seconds max.
<b>Ramp down rate</b>	3°C/second max.
<b>Time 25°C to peak temperature</b>	8 minutes max.

**Note:** All temperatures refer to topside of the package, measured on the package body surface.

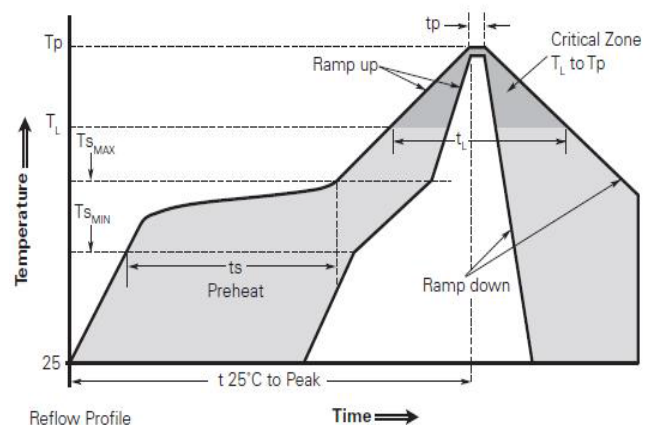

- Recommended reflow methods: IR, vapor phase oven, hot air oven, N2 environment for lead-free.
- Devices are not designed to be wave soldered to the bottom side of the board.
- Recommended maximum paste thickness is 0.25mm (0.010inch).
- Devices can be cleaned using standard industry methods and solvents.
- Soldering temprature profile meets RoHs leadfree process.

Notes: If reflow temperatures exceed the recommended profile, devices may not meet the performance requirements

## Tape Specification And Reel Dimensions

Covering Specifications EIA 481-1(Unit:mm)	
W	8.00± 0.10
P <sub>0</sub>	4.0 ± 0.10
P <sub>1</sub>	4.0± 0.10
P <sub>2</sub>	2.0 ± 0.05
A <sub>0</sub>	0.95 ± 0.10
B <sub>0</sub>	1.85± 0.05
D <sub>0</sub>	1.55± 0.05
F	3.50± 0.05
E <sub>1</sub>	1.75 ± 0.10
T	0.20± 0.02
Leader min.	390
Trailer min.	160
Reel Dimensions	
A	178±1.0
N	59±1
W <sub>1</sub>	8.5+1.0/-0.2
W <sub>2</sub>	12.0±1

### EIA Tape Component Dimintions

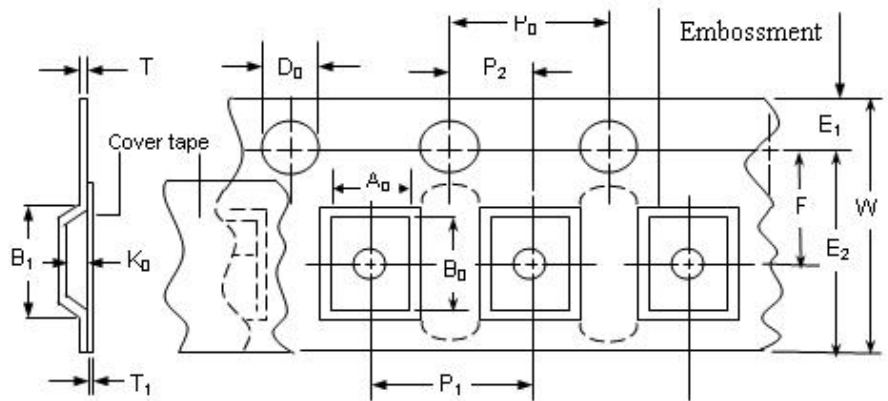

### EIA Reel Dimintions

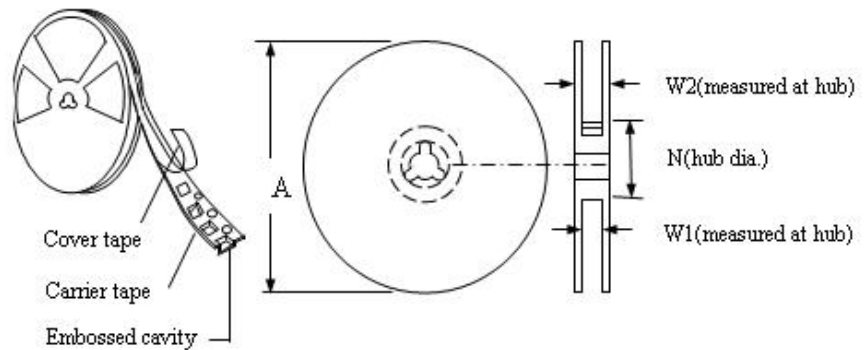

## Packaging Quantity

Model	Quantity	Model	Quantity
JK-SMD0603-005	5000	JK-SMD0603-025	5000
JK-SMD0603-010	5000	JK-SMD0603-030	4000
JK-SMD0603-020	5000	JK-SMD0603-035	4000



## Storage

The maximum ambient temperature shall not exceed 38°C. Storage temperatures higher than 38°C could result in the deformation of packaging materials. The maximum relative humidity recommended for storage is 60%. High humidity with high temperature can accelerate the oxidation of the solder plating on the termination and reduce the solderability of the components. Sealed plastic bags with desiccant shall be used to reduce the oxidation of the termination and shall only be opened prior to use. The products shall not be stored in areas where harmful gases containing sulfur or chlorine are present

